



## INSTALLATION AND OPERATING INSTRUCTIONS MC P2 MODBUS MS / TP SERIES

### MC P2 MODBUS MS / TP



This manual is suitable for the following products:

- MC P2 Modbus MS / TP (01077050)
- MC P2 Modbus MS / TP VRS (01077052)
- MC P2 Complete Modbus MS / TP (01077055)
- MC P2 Complete Modbus MS / TP VRS (01077057)

Documentnumber: 85900626 A1

Programmable motor controls for operating 2 motors with central, group and individual control; available for wired switches and wireless (VRS) control, available in different housing types.

Read the manual before starting the installation.  
Failure to follow the instructions may result in defects that are not covered by the warranty. Errors and technical changes excepted.



## CONTENT

■ Safety precautions	2	■ MC P2 Modbus MS/TP	14
■ Variants	3	■ MC P2 Modbus MS/TP Register Overview	24
■ Technical data	3	■ Programming VRS Transmitter	28
■ Installation / Wiring diagram / Operation	4	■ Warranty / Maintenance	32
■ IDS Function	7		
■ Functional description	7		
■ MC P2 Modbus MS/TP implementation	13		

## SAFETY PRECAUTIONS

### GENERAL INFORMATION

These safety instructions are part of the product and must be fully read and understood before installation, electrical connection, commissioning and use.

- The device may only be used for its intended purpose (control of up to two 230 V sun shading motors, wired or via VRS radio).
- Installation, wiring and commissioning may only be carried out by qualified electrical personnel.
- National regulations, VDE standards (DIN VDE 0100/0700), accident prevention rules and the technical data must be observed.
- Do not install or operate the device if it shows visible damage.
- Modifications to the device are not permitted.
- The operator must ensure that all subsequent users receive these safety instructions.

### SAFETY WARNINGS



#### ELECTRICAL HAZARDS

**DANGER** – Risk of fatal electric shock.  
Disconnect the mains voltage completely before installation and before working on the device.



#### RADIO AND EMC INFORMATION

**CAUTION** – Malfunctions due to electromagnetic interference.



#### HAZARDS FROM MOVING SUN SHADING SYSTEMS | WARNING –

Risk of injury due to crushing, shear points or uncontrolled movements.



#### ELECTRICAL HAZARDS

**DANGER** – Operate the device only within the specified ambient temperature range (0–40 °C).



#### NOTE

The complete safety instructions can be found at: [www.vestamatic.com/safety](http://www.vestamatic.com/safety)



SCAN ME

## SUPPORT/CONTACT

Vestamatic International GmbH  
Am Tannenbaum 2 | 41066 Mönchengladbach  
E-Mail: [info@vestamatic.com](mailto:info@vestamatic.com)

## VARIANTS

- MC P2 MODBUS MS / TP
- MC P2 MODBUS MS / TP VRS
- MC P2 COMPLETE MODBUS MS / TP
- MC P2 COMPLETE MODBUS MS / TP VRS  
Grommets already installed (6x M16, 2x M20)



## TECHNICAL DATA

### SHORT DESCRIPTION

- Microprocessor-powered motor controller for controlling up to two rollershutter / sunshade motor, Usable for venetian blinds (factory setting) or roller blinds / screens / shutters
- Standard 3-wire central input.
- Direct connection available for two 230VAC motors.
- Connection available for two individual buttons.
- Separate connection terminals for mains supply and central transmission
- 10 different operating modes can be set, incl. inching mode and intelligent decentralised operation.
- Motor run time/tilting time can be individually set.
- Control via VRS radio remote control or VRS wall-mounted radio transmitter (MC P2 Modbus VRS).
- Control via serial bus communication protocol -RS485 Modbus RTU.

PARAMETER	VALUE
Power supply	230 VAC, 50 Hz
Impulse voltage withstand level	2,5 kV
Radio frequency (VRS variants only)	868,3 MHz
Rated power	1,8 W

## TECHNICAL DATA

PARAMETER	VALUE
Fuse	6 AT
Output	230VAC, 50 Hz
Maximum load:	250VAC, 6 A, $\cos \varphi \geq 0,8$ ind.
Align switching time extend:	3 – 180 s
Align switching time retract:	180 s
Permissible motor current when 1 motor connected	6 A max.
when 2 motor connected	3 A max. each
Operating temperature	0 °C to +40 °C
IP class:	IP 40
Dimensions (L x W x H)	186 x 55 x 74 mm
Conformität	

## INSTALLATION / WIRING DIAGRAM

### NOTES FOR PROFESSIONAL ELECTRICIANS

- 1: Switch off the power supply.
- 2: Undo the housing cover screws and lift off the housing cover.
- 3: Use the four mounting holes at the edges of the housing to mount it.
- 4: Connect the power supply cables and external connections according to the wiring diagram. Do not lay cables above or below the PC board.
- 5: Set the desired operating mode.
- 6: Set the desired motor run time and the tilting time, if necessary.
- 7: Switch on the power supply.
- 8: Check the motor's direction of rotation and correct it, if necessary.
- 9: Replace the housing cover and tighten the housing cover screws.

### CABLE RECOMMENDATION

- red: 230V (NYM 3x1.5<sup>2</sup>)
- black: (H05VV 4x0.75<sup>2</sup>)
- blue: (NYM 4x1.5<sup>2</sup>)

## INSTALLATION / WIRING DIAGRAM

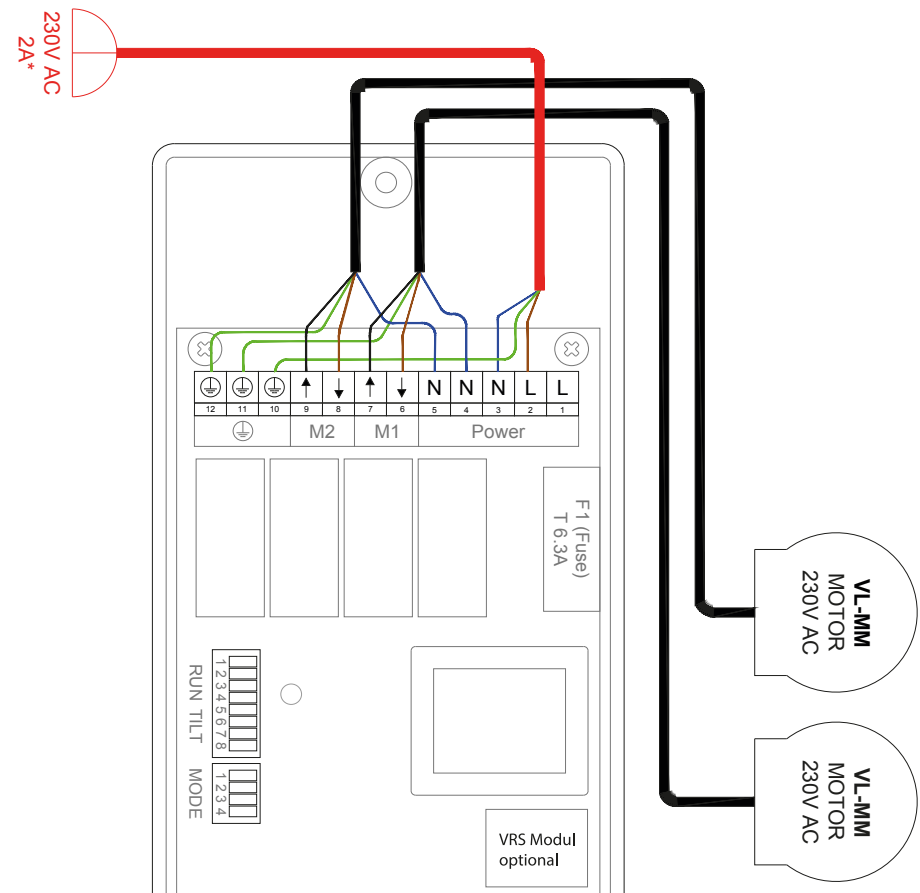

### NOTE

For MC P2 Modbus Housing and MC P2 Modbus VRS Housing: Please manually cut out for the cable connections and add a strain relief.

For MC P2 Modbus Complete/Fitted housing strain relief is included.

## INSTALLATION / WIRING DIAGRAM

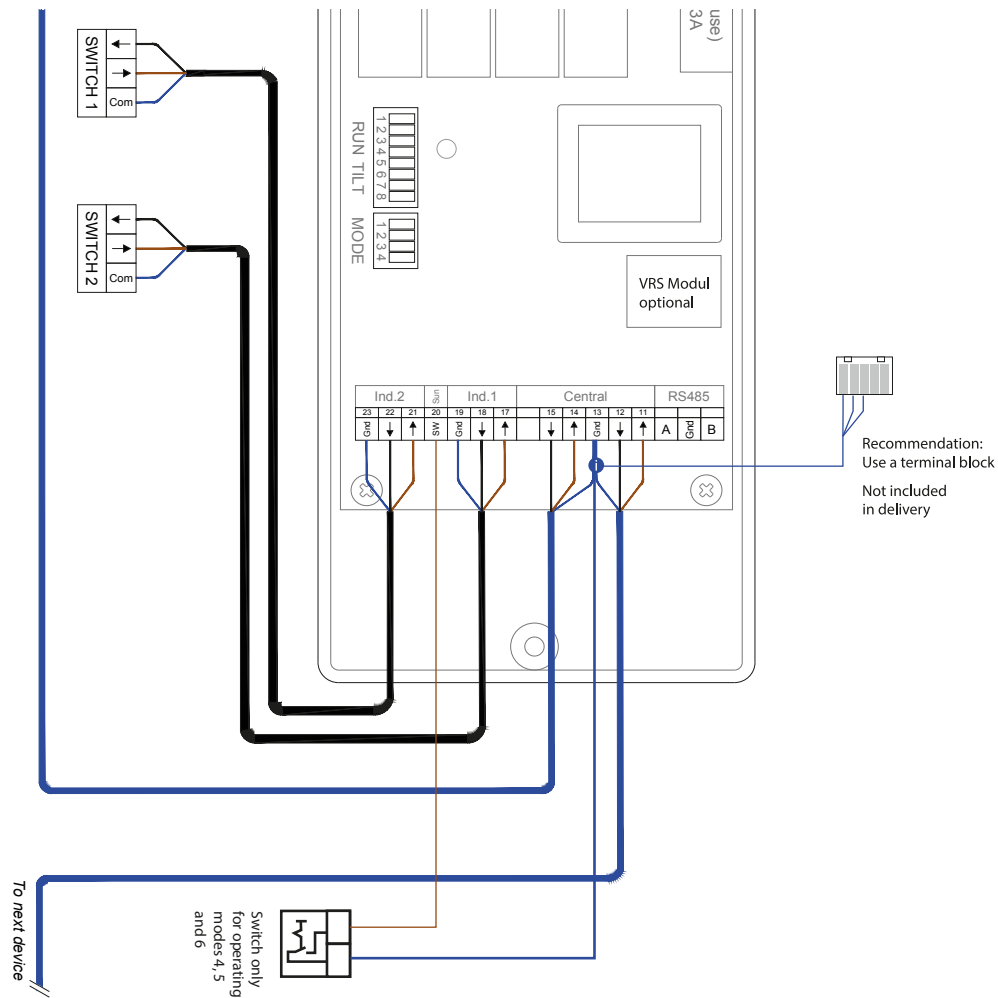

## OPERATION



## WARNING

No individual operation is possible while a central command is being executed.

Individual operation is performed by using a locked/unlocked button.



## NOTE

The following descriptions are valid for all types MC P2 Modbus MS / TP in this technical documentation

## IDS FUNCTION

- The IDS (Intelligent Decentralised Sunshade control) feature enables the sun- and temperature dependant control signals on the central controls to be disabled when a button is pressed on the decentralised controls. No additional installation work is required.
- In operating mode 4 the IDS-Function enables you to suppress sun- and temperature dependent extract or extend commands while all other central commands, such as for privacy and safety protection use are continuously executed. To enable this function connect a switch to A/H input and Common (-).
- In operating modes 9 and 10, the sun- or temperature-dependent central commands are masked by pressing the group or individual button. All further sun- and temperature-dependent retract/extend commands will then be masked for 4 hours. Each additional operation via the individual command will result in the sun or temperature-dependent central com-mands being masked for a further 4 hours.
- After the set period has elapsed, the MC P2 Modbus control will be reset automatically and all sun- and temperature-dependent central controls will then be executed as normal.



Shutters



Roller Blinds



Screens



Awning



Venetian Blinds

## FUNCTIONAL DESCRIPTION



## WARNING!

The operating modes 4 to 6, 9 and 10 may only be used in conjunction with Vestamatic controls with IDS functionality.

## OPERATING MODE 1 | APPLICATION

## Standard venetian blinds / curtains

**Individual control:** Pressing the control button for more than 2 seconds moves the sun shading to the end position.

With a short button press (under 2 seconds), the sun shading moves only while the button is held. **Central control:** The sun shading is operated in hold-to-run mode.

## OPERATING MODE 2 | APPLICATION

## Venetian blinds / curtains with soft start

Same operation as Mode 1, but with a soft start. If the control button is pressed for more than 5 seconds, the sun shading moves to the end position.

## FUNCTIONAL DESCRIPTION

## OPERATING MODE 3 | APPLICATION

## Roller shutters

**Individual control:** Pressing the button moves the sun shading immediately to the end position. **Central control:** The sun shading is operated in hold-to-run mode.

## OPERATING MODE 4 | APPLICATION

## IDS venetian blinds / curtains with autom. lock

**Individual control:** Pressing the control button for more than 2 seconds moves the sun shading to the end position. With a short button press (under 2 seconds), the sun shading moves in hold-to-run mode. **Central commands:** Sun- and temperature-dependent central commands can be suppressed via a switch connected to terminals 31/32.

## OPERATING MODE 5 | APPLICATION

## IDS special venetian blinds / curtains

Same as Operating Mode 4, but with special function 1 (Tilting via individual control possible)

## OPERATING MODE 6 | APPLICATION

## IDS special venetian blinds / curtains

Same as Operating Mode 4, but with special function 2 (Tilting via individual control possible).

## OPERATING MODE 7 | APPLICATION

## Rolläden

**Individual control:** Pressing the button moves the sun shading immediately to the end position. **Central control:** Pressing the control button moves the sun shading immediately to the end position.

## OPERATING MODE 8 | APPLICATION

## Venetian blinds / curtains without soft start

**Individual control:** Pressing the control button for more than 2 seconds moves the sun shading to the end position. With a short button press (under 2 seconds), the sun shading moves in hold-to-run mode. **Central control:** Pressing the control button for more than 2 seconds moves the sun shading to the end position.

## OPERATING MODE 9 | APPLICATION

## IDS venetian blinds / curtains – 4-hour lock

**Individual control:** Pressing the control button for more than 2 seconds moves the sun shading to the end position. With a short button press (under 2 seconds), the sun shading moves in hold-to-run mode. **Central commands:** Sun- and temperature-dependent central commands are suppressed for 4 hours by pressing the individual control button.

## OPERATING MODE 10 | APPLICATION

## IDS venetian blinds / curtains – 4-hour lock

**Individual control:** Pressing the control button for more than 2 seconds moves the sun shading to the end position. **Central commands:** Sun- and temperature-dependent central commands are suppressed for 4 hours by pressing the individual control button.

## FUNCTIONAL DESCRIPTION



## NOTE

Pressing an individual button will only block that particular output from sun and temperature-dependent central commands for 4 hours (adjustable).

When performing work on the windows, controls or connected shades, protect them against unauthorised or unintentional operation.

## RUN TIME OF THE EXTEND COMMAND

DIP switch RUN:					
DIP 1	DIP 2	DIP 3	DIP 4	RUN TIME	*
The duration of the retract command is always 180 s. **					
OFF	OFF	OFF	OFF	5s	
OFF	OFF	OFF	ON	10s	
OFF	OFF	ON	OFF	15s	
OFF	OFF	ON	ON	18s	
OFF	ON	OFF	OFF	21s	
OFF	ON	OFF	ON	24s	
OFF	ON	ON	OFF	27s	
OFF	ON	ON	ON	30s	
ON	OFF	OFF	OFF	35s	
ON	OFF	OFF	ON	40s	
ON	OFF	ON	OFF	50s	
ON	OFF	ON	ON	60s	
ON	ON	OFF	OFF	80s	
ON	ON	OFF	ON	100s	
ON	ON	ON	OFF	120s	
ON	ON	ON	ON	180s	default settings

\* This is where you can note your project-specific basic settings.

\*\* The set run time can be overwritten by RS485, the last configured value will be used.

## FUNCTIONAL DESCRIPTION

## OPERATION MODE

DIP switch MODE:							
							
DIP 1	DIP 2	DIP 3	DIP 4	OPERATING MODE		TILTING	*
				No.	Application		
OFF	OFF	OFF	OFF	1	standard Venetian blinds / Curtain blinds	possible only via central command	
OFF	OFF	OFF	ON	2	Venetian blinds Curtain blinds with slow start velocity	possible only via central command	
OFF	OFF	ON	OFF	3	Roller shutters	possible only via central command	
OFF	OFF	ON	ON	4	IDS Venetian bl./Curtain bl with autom. interlock	Adjustable, 0-2s	
OFF	ON	OFF	OFF	5	IDS spec. Venetian blinds/ Curtain blinds special function 1	Adjustable, 0-5s	
OFF	ON	OFF	ON	6	IDS spec. Venetian blinds/ Curtain blinds special function 2	Adjustable, 0-2s	
OFF	ON	ON	OFF	7	Roller shutters	No Tilting possible	
OFF	ON	ON	ON	8	Venetian blinds without slow start velocity	possible only via central command	
ON	OFF	OFF	OFF	9	IDS Venetian bl./Curtain bl 4h locking	Adjustable, 0-2s	
ON	OFF	OFF	ON	10	IDS Venetian bl./Curtain bl 4h locking	Adjustable, 0-2s	



Shutters



Roller Blinds



Screens



Awnings

Venetian  
Blinds

## FUNCTIONAL DESCRIPTION

## TILTING TIME

## TILTING TIME TABLE FOR MODE 4, 6, 9, 10

Depending on the operating mode selected one of the following tables shall apply for setting the required tilting time. The tilting time will only be executed after a central command!

DIP switch TILT:					
					
DIP 5	DIP 6	DIP 7	DIP 8	TILTING TIME	*
OFF	OFF	OFF	OFF	no tilting	default settings
OFF	OFF	OFF	ON	0.1s	
OFF	OFF	ON	OFF	0.2s	
OFF	OFF	ON	ON	0.3s	
OFF	ON	OFF	OFF	0.4s	
OFF	ON	OFF	ON	0.5s	
OFF	ON	ON	OFF	0.6s	
OFF	ON	ON	ON	0.7s	
ON	OFF	OFF	OFF	0.8s	
ON	OFF	OFF	ON	0.9s	
ON	OFF	ON	OFF	1.0s	
ON	OFF	ON	ON	1.2s	
ON	ON	OFF	OFF	1.4s	
ON	ON	OFF	ON	1.6s	
ON	ON	ON	OFF	1.8s	
ON	ON	ON	ON	2.0s	

\* This is where you can note your project-specific basic settings.

## FUNCTIONAL DESCRIPTION

### TILTING TIME

#### TILTING TIME TABLE FOR MODE 5

Depending on the operating mode selected one of the following tables shall apply for setting the required tilting time. The tilting time will only be executed after a central command!

DIP switch TILT:					
DIP 5	DIP 6	DIP 7	DIP 8	TILTING TIME	*
OFF	OFF	OFF	OFF	no tilting	default settings
OFF	OFF	OFF	ON	0.4s	
OFF	OFF	ON	OFF	0.7s	
OFF	OFF	ON	ON	1.0s	
OFF	ON	OFF	OFF	1.3s	
OFF	ON	OFF	ON	1.6s	
OFF	ON	ON	OFF	1.9s	
OFF	ON	ON	ON	2.2s	
ON	OFF	OFF	OFF	2.5s	
ON	OFF	OFF	ON	2.8s	
ON	OFF	ON	OFF	3.1s	
ON	OFF	ON	ON	3.4s	
ON	ON	OFF	OFF	3.7s	
ON	ON	OFF	ON	4.0s	
ON	ON	ON	OFF	4.5s	
ON	ON	ON	ON	5.0s	

\* This is where you can note your project-specific basic settings.

## MC P2 MODBUS MS/TP IMPLEMENTATION

### SETUP

By pressing the PROG button of the MC P2 shortly (< 1 second), the Modbus setup mode will be entered. Use a standard terminal program with following fixed communication settings:

**BAUD RATE: 57600**

**DATA BITS: 8**

**STOPBITS: 1**

**PARITY: NONE**

**FOLLOWING SETTINGS CAN BE MADE:**

```

MODBUS settings:
Address 'adr,x'(1-247): 1
Baud rate 'bdr,x'(1-4800, 2=9600, 3=19200): 19200
Parity 'par,x'(1=odd, 2=even, 3=none): EVEN
~
MOTOR settings:
Motor 1 DOWN runtime 'md1,x'(0.1-409.5): 180.0 sec
      UP runtime 'mu1,x'(0.1-409.5): 180.0 sec
Motor 2 DOWN runtime 'md2,x'(0.1-409.5): 180.0 sec
      UP runtime 'mu2,x'(0.1-409.5): 180.0 sec
Motor reverse time 'rev,x'(0.3-2.5): 0.4 sec
Central block time 'blk,x'(30-1080 or 65535): 240 min
~
Save settings 'save'
Exit setup 'exit'
  
```

Save settings **'save'**

Exit setup **'exit'**

#### ADDRESS

The Modbus address can be set from 1 to 247. To change the current address, enter:

adr,x

where 'x' is the new address.

#### BAUD RATE

The Modbus baud rate can be set to 4800, 9600 or 19200 baud. To change the current baud rate, enter:

bdr,x

where 'x' is

- 1 when using 4800 baud,
- 2 when using 9600 baud or
- 3 when using 19200 baud.

#### PARITY

The Modbus parity can be set to odd, even or none.

To change the current parity mode, enter:

par,x

where 'x' is

- 1 when using odd parity
- 2 when using even parity
- 3 when using none parity

#### RUNTIME

The motor runtime can be set for each channel for UP and DOWN direction. Runtime UP must be equal or higher than the DOWN runtime.

md1,x	DOWN runtime motor 1 {channel 1}
mu1,x	UP runtime motor 1 {channel 1}
md2,x	DOWN runtime motor 2 {channel 2}
mu2,x	UP runtime motor 2 {channel 2}

where 'x' is runtime in seconds, and may have 1 fraction digit.

E.g.: md1,110.1 will set DOWN runtime motor 1 {channel 1} to 110.1 seconds.

## MC P2 MODBUS MS/TP IMPLEMENTATION

### REVERSE TIME

The time between opposite {UP-DOWN or DOWN-UP} commands is default set to 0.4

seconds. To change the reverse time, enter:

rev,x

where ,x' is the reverse time in seconds, and may have 1 fraction digit.

### CENTRAL BLOCKING TIME

Central blocking time (operation mode 9 & 1 O) is default set to 240 minutes (4 hours).

blk,x

where ,x' is the central blocking time in minutes.

### SAVE

Enter save to store new settings.

### EXIT

Enter exit to leave the Modbus setup mode. A time-out of 60 seconds closes the Modbus setup mode automatically when no input is received. Any changes made to the Modbus Settings will be lost when not saved with the save command.

## MC P2 MODBUS MS/TP

### DISCRETE INPUTS: GET SWITCH INPUT STATE

Read actual state of physical switch inputs. Accessible with Read Discrete Inputs (Ox02) command.

Register address	Modbus protocol start address	Field name	Description	Result
10001	0x0000	INDV1_UP	Individual input 1 UP state	1 = active / 0 = inactive
10002	0x0001	INDV1_DOWN	Individual inout 1 DOWN state	1 = active / 0 = inactive
10003	0x0002	INDV2_UP	Individualinput 2 UP state	1 = active / 0 = inactive
10004	0x0003	INDV2_DOWN	Individual inout 2 DOWN state	1 = active / 0 = inactive
10011	0x000A	CENTRALUP	Central input UP state	1 = active / 0 = inactive
10012	0x000B	CENTRALDOWN	Central input DOWN state	1 = active / 0 = inactive
10013	0x000C	A.H	Automatic/manual state	1 = active / 0 = inactive

## MC P2 MODBUS MS/TP

### DISCRETE INPUTS: GET RELAYS OUTPUT STATE

Read actual relay output state. Accessible with Read Discrete Inputs (Ox02) command.

Register address	Modbus protocol start address	Field name	Description	Result
10017	0x0010	MOT1_UP	Motor 1 UP relay state	1 = active / 0 = inactive
10018	0x0011	MOT1_DOWN	Motor 1 DOWN relay state	1 = active / 0 = inactive
10019	0x0012	MOT2_UP	Motor 2 UP relay state	1 = active / 0 = inactive
10020	0x0013	MOT2_DOWN	Motor 2 DOWN relay state	

### DISCRETE INPUTS: GET CENTRAL COMMAND BLOCKED STATE

Read central commands are currently blocked state. Accessible with Read Discrete Inputs (Ox02) command.

Register address	Modbus protocol start address	Field name	Description	Result
10025	0x0018	CENTRAL1_BLOCKED	Channel 1 central commands	1 =yes / 0=no
10026	0x0019	CENTRAL2_BLOCKED	Channel 2 central commands	1 = yes / 0 = no

### GET INDIVIDUAL SWITCH INPUTS: HARD-WIRED

Read actual state of the individual hard-wired switch inputs. Accessible with Read Discrete Inputs (Ox02) command.

Register address	Modbus protocol start address	Field name	Description	Result
10029	0x001C	INDV1_UP WIRED	Individual input 1 wired UP state	1 = active / 0 = inactive
10030	0x001D	INDV1_DOWN_WIRED	Individual input 1 wired DWN state	1 = active / 0 = inactive
10031	0x001E	INDV2_UP_WIRED	Individual input 2 wired UP state	1 = active / 0 = inactive
10032	0x001F	INDV2_DOWN_WIRED	Individual input 2 wired DOWN state	1 = active / 0 = inactive



#### REMARK:

When register 40027 „Individual inputs extend read“ is set, this will be taken into account for registers 10029,10032 Individual input 1,2 wired UP/DOWN state.

## MC P2 MODBUS MS/TP

### GET INDIVIDUAL SWITCH INPUTS: RADIO

Read actual state of the individual radio switch inputs. Accessible with Read Discrete Inputs (0x02) command.

Register address	Modbus protocol start address	Field name	Description	Result
10037	0x0024	INDV1_UP_RADIO	Individual input 1 radio UP state	1 = active / 0 = inactive
10038	0x0025	INDV1_DOWN_RADIO	Individual input 1 radio DOWN state	1 = active / 0 = inactive
10039	0x0026	INDV2_UP_RADIO	Individual input 2 radio UP state	1 = active / 0 = inactive
10040	0x0027	INDV2_DOWN_RADIO	Individual input 2 radio DOWN state	1 = active / 0 = inactive

When register 40027 „Individual inputs extend read“ is set, this will be taken into account for registers 10037 .. 10040 Individual input 1 .. 2 radio UP/DOWN state.

### GET INDIVIDUAL SWITCH INPUTS: MODBUS

Read actual state of the individual Modbus switch inputs. Accessible with Read Discrete Inputs (0x02) command.

Register address	Modbus protocol start address	Field name	Description	Result
10045	0x002C	INDV1_UP_MBUS	Individual input 1 Modbus UP state	1 = active / 0 = inactive
10046	0x002D	INDV1_DOWN_MBUS	Individual input 1 Modbus DOWN state	1 = active / 0 = inactive
10047	0x002E	INDV2_UP_MBUS	Individual input 2 Modbus UP state	1 = active / 0 = inactive
10048	0x002F	INDV2_DOWN_MBUS	Individual input 2 Modbus DOWN state	1 = active / 0 = inactive

## MC P2 MODBUS MS/TP

### COILS: SET SWITCH INPUTS STATE

Overwrite physical switch inputs. As long as an input is set active, physical connected switch will be suppressed. Accessible with Write Multiple Coils (0x0F) or Write Single Coil (0x05) command.

Register address	Modbus protocol start address	Field name	Description	Result
1	0x0000	INDV1_UP	Individual input 1 UP state	1 = active / 0 = inactive
2	0x0001	INDV1_DOWN	Individual input 1 DOWN state	1 = active / 0 = inactive
3	0x0002	INDV2_UP	Individual input 2 UP state	1 = active / 0 = inactive
4	0x0003	INDV2_DOWN	Individual input 2 DOWN state	1 = active / 0 = inactive
11	0x000A	CENTRAL_UP	Central input UP state	1 = active / 0 = inactive
12	0x000B	CENTRAL_DOWN	Central input DOWN state	1 = active / 0 = inactive
13	0x000C	A_H	Automatic/manual state	1 = active / 0 = inactive



#### REMARK:

- 1) When both UP and DOWN are set to 1, UP has highest priority and will be executed.
- 2) When writing to Switch input registers, the selected operation mode ergonomics will be respected and setting the switch state over Modbus reacts in the exact same way as a physical connected switch will do.
- 3) Setting a switch input to active state (1), this should be refreshed at least once every 30 seconds to remain the active state. After a timeout of 60 seconds the switch input state automatically changes to inactive (0).

### INPUT REGISTERS: GET CONFIGURATION

Accessible with Read Input Register (0x04)

Register address	Modbus protocol start address	Field name	Description	Result
30001	0x0000	DIP_OPERATION_MODE	Dipswitch operation mode	0 ..13
30002	0x0001	DIP_RUN_TIME	Dipswitch running time	0 .. 180 seconds
30003	0x0002	DIP_TILT_TIME	Dipswitch tilting time	0 .. 5000 milli-seconds

## MC P2 MODBUS MS/TP

## INPUT REGISTERS: GET POSITION

Accessible with Read Input Register (0x04)

Register address	Modbus protocol start address	Field name	Description	Result
30004	0x0003	MOT1_PERC_POS	Motor 1 position	0 ..100% (0% = upper pos.)
30005	0x0004	MOT2_PERC_POS	Motor 2 position	0 ..100%

## INPUT REGISTER: GET RUNTIME

Accessible with Read Input Register (0x04)

Register address	Modbus protocol start address	Field name	Description	Result
30008	0x0007	MOT1_RUN_UP	Motor 1 runtime UP	1.. 4095 (0.1.. 409.5 sec)
30009	0x0008	MOT1_RUN_DOWN	Motor 1 runtime DOWN	1.. 4095 (0.1.. 409.5 sec)
30010	0x0009	MOT2_RUN_UP	Motor 2 runtime UP	1.. 4095 (0.1.. 409.5 sec)
30011	0x000A	MOT2_RUN_DOWN	Motor 2 runtime DOWN	1.. 4095 (0.1.. 409.5 sec)

## INPUT REGISTER: GET CENTRAL COMMAND BLOCK TIME

Accessible with Read Input Register (0x04)

Register address	Modbus protocol start address	Field name	Description	Result
30016	0x000F	CENTRAL_BLOCK TIME	Central command block time	30 .. 1080 (minutes) 65535 = infinite

## SET CENTRAL COMMAND BLOCKED STATE

Activate or deactivate central command blocked state. Accessible with Write

Multiple Coils (0x0F) or Write Single Coil (0x05) command.

Register address	Modbus protocol start address	Field name	Description	Result
25	0x0018	BLOCK_CENTRAL_1	Block central commands channel 1	1 = yes / 0 = no
26	0x0019	BLOCK_CENTRAL_2	Block central commands channel 2	1 =yes/0=no

## MC P2 MODBUS MS/TP



## REMARK:

- 1) Activating the central commands blocked state has only affect when operation mode 9 or 1 0 is selected.
- 2) When activating a central command block state, automatic central commands are blocked for a duration of the given „central command block time“.

## INPUT REGISTER: GET WIRED INPUTS &amp; RADIO CONNECT STATE

Accessible with Read Input Register (0x04)

Register address	Modbus protocol start address	Field name	Description	Result
30017	0x0010	INPUT_RADIO_CONNECT	Local inputs & radio connect state	CONNECT_STATE

## CONNECT\_STATE bit-layout:

15	14	13	12	11	10	9	8	7	6	5	4	3	2	1	0
					A_H	CENT	-	-	-	RAD2	RAD1	-	-	INV2	INV1

**INDV1..2** 0 = Hard-wired individual input is connected

1 = Hard-wired individual input is not connected (no function)

**RAD1..2** 0 = Radio channel is connected

1 = Radio channel is not connected (no function)

**CENT** 0 = Hard-wired central input is connected

1 = Hard-wired central input is not connected (no function)

**A\_H** 0 = Hard-wired automatic/manual input is connected

1 = Hard-wired automatic/manual input is not connected (no function)

## MC P2 MODBUS MS/TP

**HOLDING REGISTER: STEER**

Send central, group or individual steer commands. Writing a steer command, will bypass the switch ergonomics and executes this command (when possible, when no higher priority command is active). Opposite steer commands will respect the reverse delay (410 msec.). Accessible with Write Single Register (0x06) or Write Multiple Registers (0x10) command.

**GROUP OR INDIVIDUAL steer command have following bit-layout:**

15	14	13	12	11	10	9	8	7	6	5	4	3	2	1	0
-	ACTION			RUNTIME											

**AKTION** 0 = no action

1 = STOP

2 = UP

3 = DOWN

4 = STORE\_RUNTIME MC P2 Standard = only DOWN runtime

5 = STORE\_RUNTIME\_UP Store UP runtime. UP runtime >= DOWN runtime

6 = STORE\_RUNTIME\_DOWN Store DOWN runtime. Down runtime <= UP runtime

**RUNTIME** Runtime is defined in 1/10th seconds. A runtime of 0 (zero) will set the runtime as local.

STORE\_RUNTIME, STORE\_RUNTIME\_UP or

STORE\_RUNTIME\_DOWN would store the given runtime in EEPROM for given channel. A runtime of 0 (zero) is not valid for this command.

**Example:**

RUNTIME = 0x00A / 10 > action runtime is 1.0 sec.

0x4B0 / 1200 > action runtime is 120.0 sec.

0xFF / 4095 > action runtime is 409.5 sec. (max runtime)

**CENTRAL steer command have following bit-layout:**

15	14	13	12	11	10	9	8	7	6	5	4	3	2	1	0
TYPE	ACTION	LOCAL	RUNTIME												

**TYPE** 0 = Central safety/priority command (e.g. wind safety command).

1 = Central automatic command (e.g. sun or temperature command).

**ACTION** 0 = no action

1 = STOP

2 = UP

3 = DOWN

**LOCAL** 0 = use RUNTIME as runtime for this action.

1 = use LOCAL defined runtime for this action.

## MC P2 MODBUS MS/TP

**CENTRAL steer command have following bit-layout:**

**RUNTIME** Runtime for this action defined in 1/10th seconds. A runtime of 0 (zero) will set the runtime infinite.

**Example:**

RUNTIME = 0x000 / 0 > action runtime is infinite (till next central command)

0x00A / 10 > action runtime is 1.0 sec.

0x4B0 / 1200 > action runtime is 120.0 sec.

0xFF / 4095 > action runtime is 409.5 sec. (max runtime)

Register address	Modbus protocol start address	Field name	Description	Result
40001	0x0000	STEER_INDV1	Steer individual channel1	Group/individual steer cmd
40002	0x0001	STEER_INDV2	Steer individual channel2	Group/individual steer cmd
40006	0x0005	STEER_CENTRAL	Steer central	Central steer cmd

**REMARK:**

- 1) ACTION = 0 (no action) will do nothing. Can be used to skip certain registers when using Write Multiple Registers.
- 2) ACTION = 1 (STOP) will not take runtime (local or user) into account.
- 3) LOCAL = 1 will ignore RUNTIME field

**HANDLING OF LOCAL INPUTS, RADIO INPUTS AND MODBUS COMMANDS**

- Hard-wired switch commands, radio switch commands or steer commands received over the Modbus, how will this be handled inside of the MC P2?
- In the „old“ MC P2 (without Modbus), the hard-wired switches and the radio switches were logically „OR-ed“ and the result was used to control the individual channels. When both UP and DOWN were pressed, UP has priority above DOWN.
- With the Modbus addition, it is no longer possible to logically OR all these inputs. A new approach will be used in the MC P2 Modbus MS / TP:
- The MC P2 will handle the input source (hard-wired, radio or Modbus) that last changes. For hard-wired and radio commands, key-release actions are only handled when the „active“ input source is unchanged.

**EXAMPLE 1**

Hard-wired INDV1 UP pressed → Channel1 UP active  
 Hard-wired INDV1 UP released (< 2 sec.) → Channel1 UP inactive

**EXAMPLE 2**

Hard-wired INDV1 UP pressed → Channel1 UP active  
 Radio INDV1 UP pressed → Channel1 UP remains active  
 Hard-wired INDV1 UP released (< 2 sec.) → Ignored, channel1 UP remains active  
 Radio INDV1 UP released (> 2 sec.) → Channel1 UP remains active for 180 sec.

## MC P2 MODBUS MS/TP

## HANDLING OF LOCAL INPUTS, RADIO INPUTS AND MODBUS COMMANDS

- When steering channel1 hard-wired UP, and will be overruled by radio down, the first radio DOWN command will stop the UP movement. A second radio DOWN command is needed to start channel1 DOWN.
- When steering channel1 hard-wired UP, and will be overruled by Modbus down, only a group/individual steer DOWN command register write to address 40001 is needed. In between the UP and DOWN channel movement, a reverse delay is implemented of 410 msec.

## HOLDING REGISTER: ABSOLUTE POSITION

Central or individual absolute position registers to steer motor to an absolute position. A percentage value will represent the absolute position were 0% is upper limit and 100% is lower limit. Writing an absolute position will bypass the switch ergonomics and executes this command (when possible, when no higher priority command is active). Opposite steer commands will respect the reverse delay (410 msec.). Accessible with Write Single Register (0x06) or Write Multiple Registers (0x10) command.

**INDIVIDUAL absolute position registers have following bit-layout:**

15	14	13	12	11	10	9	8	7	6	5	4	3	2	1	0
										PERC_POS					

**PERC\_POS** 0 .. 100 percentage position

**INDIVIDUAL absolute position registers have following bit-layout:**

15	14	13	12	11	10	9	8	7	6	5	4	3	2	1	0
TYPE											PERC_POS				

**TYPE** 0 = Central safety/priority command (e.g. wind safety command).

1 = Central automatic command (e.g. sun or temperature command).

**PERC\_POS** 0 .. 100 percentage position

Register address	Modbus protocol start address	Field name	Description	Result
40007	0x0006	PERC_POS_INDV1	Percentage position indiv. channel1	0 .. 100% (0% = upper pos.)
40008	0x0007	PERC_POS_INDV2	Percentage position indiv. channel2	0 .. 100%
40012	0x000B	PERC_POS_CENTRAL	Percentage position central	0 .. 100%

## MC P2 MODBUS MS/TP

## HOLDING REGISTER: SET CENTRAL COMMAND BLOCK TIME

Accessible with Write Single Register (0x06) or Write Multiple Registers (0x10) command.

Register address	Modbus protocol start address	Field name	Description	Result
40013	0x000C	CENTRAL_BLOCKTIME	Central command block time	30 .. 1080 (minutes) 65535 = infinite 240 = default



## REMARK:

1) Invalid values ( $i < 30$  or  $1080 < i < 65535$ ), will be ignored.

## HOLDING REGISTER: SET WIRED &amp; RADIO CONNECT STATE

Accessible with Write Single Register (0x06) or Write Multiple Registers (0x10) command.

Register address	Modbus protocol start address	Field name	Description	Result
40014	0x000D	CONNECT_INDV1	Connect state hard-wired indiv1 input	0 = connected 10..1080 = disconnected (for i minutes) 65535 = disconnected {infinite}
40015	0x000E	CONNECT_INDV2	Connect state hard-wired indiv2 input	0 = connected 10..1080 = disconnected (for i minutes) 65535 = disconnected {infinite}
40018	0x0011	CONNECT_RAD1	Connect state radio channel1 input	0 = connected 10..1080 = disconnected (for i minutes) 65535 = disconnected {infinite}
40019	0x0012	CONNECT_RAD2	Connect state radio channel2 input	0 = connected 10..1080 = disconnected (for i minutes) 65535 = disconnected {infinite}
40023	0x0016	CONNECT_CENT	Connect state hard-wired central input	0 = connected 10..1080 = disconnected (for i minutes) 65535 = disconnected {infinite}
40024	0x0017	CONNECT_AH	Connect state hard-wired automatic/manuell input	0 = connected 10..1080 = disconnected (for i minutes) 65535 = disconnected {infinite}
40025	0x0018	CONNECT_INDV_ALL	Connect state hard-wired indiv1 .. 2	0 = connected 10..1080 = disconnected (for i minutes) 65535 = disconnected {infinite}



## REMARK:

1) Invalid values ( $0 < i < 10$  or  $1080 < i < 65535$ ), will be ignored.

2) Default connect state for all hard-wired inputs and radio channels is 0, connected.

## MC P2 MODBUS MS/TP

## REGISTER OVERVIEW

Register address	Modbus protocol start address	Field name	Description	Result
1	0x0000	INDV1_UP	Individual input 1 UP state	1 = active / 0 = inactive
2	0x0001	INDV1_DOWN	Individual input 1 DOWN state	1 = active / 0 = inactive
3	0x0002	INDV2_UP	Individual input 2 UP state	1 = active / 0 = inactive
4	0x0003	INDV2_DOWN	Individual input 2 DOWN state	1 = active / 0 = inactive
11	0x000A	CENTRAL_UP	Central input UP state	1 = active / 0 = inactive
12	0x000B	CENTRAL_DOWN	Central input DOWN state	1 = active / 0 = inactive
13	0x000C	A_H	Automatic/manual state	1 = active / 0 = inactive
25	0x0018	BLOCK_CENTRAL1	Block central commands channel 1	1 = yes / 0 = no
26	0x0019	BLOCK_CENTRAL2	Block central commands channel 2	1 = yes / 0 = no
29	0x001C	SAFETY_UP	Safety UP object	1 = active / 0 = inactive
30	0x001D	SAFETY_DOWN	Safety DOWN object	1 = active / 0 = inactive
10001	0x0000	INDV1_UP	Individual input 1 UP state	1 = active / 0 = inactive
10002	0x0001	INDV1_DOWN	Individual input 1 DOWN state	1 = active / 0 = inactive
10003	0x0002	INDV2_UP	Individual input 2 UP state	1 = active / 0 = inactive
10004	0x0003	INDV2_DOWN	Individual input 2 DOWN state	1 = active / 0 = inactive
10011	0x000A	CENTRAL_UP	Central input UP state	1 = active / 0 = inactive
10012	0x000B	CENTRAL_DOWN	Central input DOWN state	1 = active / 0 = inactive
10013	0x000C	A_H	Automatic/manual state	1 = active / 0 = inactive
10017	0x0010	CH1_UP	Channel 1 UP relay state	1 = active / 0 = inactive
10018	0x0011	CH1_DOWN	Channel 1 DOWN relay state	1 = active / 0 = inactive
10019	0x0012	CH2_UP	Channel 2 UP relay state	1 = active / 0 = inactive
10020	0x0013	CH2_DOWN	Channel 2 DOWN relay state	1 = active / 0 = inactive
10025	0x0018	CENTRAL1_BLOCKED	Channel 1 central commands blocked	1 = yes / 0 = no
10026	0x0019	CENTRAL2_BLOCKED	Channel 2 central commands blocked	1 = yes / 0 = no
10029	0x001C	INDV1_UP_WIRED	Individual input 1 wired UP state	1 = active / 0 = inactive
10030	0x001D	INDV1_DOWN_WIRED	Individual input 1 wired DOWN state	1 = active / 0 = inactive
10031	0x001E	INDV2_UP_WIRED	Individual input 2 wired UP state	1 = active / 0 = inactive
10032	0x001F	INDV2_DOWN_WIRED	Individual input 2 wired DOWN state	1 = active / 0 = inactive
10037	0x0024	INDV1_UP_RADIO	Individual input 1 radio UP state	1 = active / 0 = inactive
10038	0x0025	INDV1_DOWN_RADIO	Individual input 1 radio DOWN state	1 = active / 0 = inactive
10039	0x0026	INDV2_UP_RADIO	Individual input 2 radio UP state	1 = active / 0 = inactive
10040	0x0027	INDV2_DOWN_RADIO	Individual input 2 radio DOWN state	1 = active / 0 = inactive
10045	0x002C	INDV1_UP_MBUS	Individual input 1 Modbus UP state	1 = active / 0 = inactive
10046	0x002D	INDV1_DOWN_MBUS	Individual input 1 Modbus DOWN state	1 = active / 0 = inactive
10047	0x002E	INDV2_UP_MBUS	Individual input 2 Modbus UP state	1 = active / 0 = inactive
10048	0x002F	INDV2_DOWN_MBUS	Individual input 2 Modbus DOWN state	1 = active / 0 = inactive
30001	0x0000	DIP_OPERATION_MODE	Dipswitch operation mode	0 .. 13
30002	0x0001	DIP_RUN_TIME	Dipswitch running time	0 .. 180 seconds
30003	0x0002	DIP_TILT_TIME	Dipswitch tilting time	0 .. 5000 milliseconds
30004	0x0003	CH1_PERC_POS	Channel 1 position	0 .. 100 %

## MC P2 MODBUS MS/TP

## REGISTER OVERVIEW

Register address	Modbus protocol start address	Field name	Description	Result
30005	0x0004	CH2_PERC_POS	Channel 2 position	0 .. 100 %
30008	0x0007	CH1_RUN_UP	Channel 1 runtime UP	1 .. 4095 (0.1 .. 409.5 s)
30009	0x0008	CH1_RUN_DOWN	Channel 1 runtime DOWN	1 .. 4095 (0.1 .. 409.5 s)
30010	0x0009	CH2_RUN_UP	Channel 2 runtime UP	1 .. 4095 (0.1 .. 409.5 s)
30011	0x000A	CH2_RUN_DOWN	Channel 2 runtime DOWN	1 .. 4095 (0.1 .. 409.5 s)
30016	0x000F	CENTRAL_BLOCK_TIME	Central command block time	30 .. 1080 minutes / 65535 = infinite
30017	0x0010	INPUT_RADIO_CONNECT	Local inputs & radio connect state	Connect state
30018	0x0011	APP_VERSION_H	Software version of the application	Bits: SW version
30019	0x0012	APP_VERSION_L	Software version of the application	Bits: SW version
30020	0x0013	REVERSE_TIME	Motor reverse time	3 .. 25 (0.3 .. 2.5 s)
40001	0x0000	STEER_INDV1	Steer individual channel 1	Individual steer cmd
40002	0x0001	STEER_INDV2	Steer individual channel 2	Individual steer cmd
40006	0x0005	STEER_CENTRAL	Steer central	Central steer cmd
40007	0x0006	PERC_POS_INDV1	Percentage position individual channel 1	0 .. 100 %
40008	0x0007	PERC_POS_INDV2	Percentage position individual channel 2	0 .. 100 %
40012	0x000B	PERC_POS_CENTRAL	Percentage position central	0 .. 100 %
40013	0x000C	CENTRAL_BLOCK_TIME	Central command block time	30 .. 1080 minutes / 65535 = infinite
40014	0x000D	CONNECT_INDV1	Connect state hard-wired indiv1 input	0, 10 .. 1080 or 65535
40015	0x000E	CONNECT_INDV2	Connect state hard-wired indiv2 input	0, 10 .. 1080 or 65535
40018	0x0011	CONNECT_RAD1	Connect state radio channel 1 input	0, 10 .. 1080 or 65535
40019	0x0012	CONNECT_RAD2	Connect state radio channel 2 input	0, 10 .. 1080 or 65535
40023	0x0016	CONNECT_CENT	Connect state hard-wired central input	0, 10 .. 1080 or 65535
40024	0x0017	CONNECT_A_H	Connect state hard-wired auto/manual input	0, 10 .. 1080 or 65535
40025	0x0018	CONNECT_INDV_ALL	Connect state hard-wired individual inputs 1..2	0, 10 .. 1080 or 65535
40026	0x0019	CONNECT_RAD_ALL	Connect state radio inputs 1..2	0, 10 .. 1080 or 65535
40027	0x001A	INDV_EXTEND_READ	Individual input extend read	0 = default / 1 .. 10
40029	0x001C	HEART_BEAT	Heart beat timeout and action	Bit 15: Action / Bit 14-0: Timeout
40030	0x001D	REVERSE_TIME	Motor reverse time	4 (0.4 s = default)

## PROGRAMMING VRS TRANSMITTER



**NOTE**

The following descriptions are valid only for the radio version MC P2 Modbus MS / TP VRS.

**BUTTON DESCRIPTION**

VRS Transmitter 5c  
(Art-No 01580070)

VRS Transmitter 10c  
(Art-No 01580080)



Programm Button at the back side

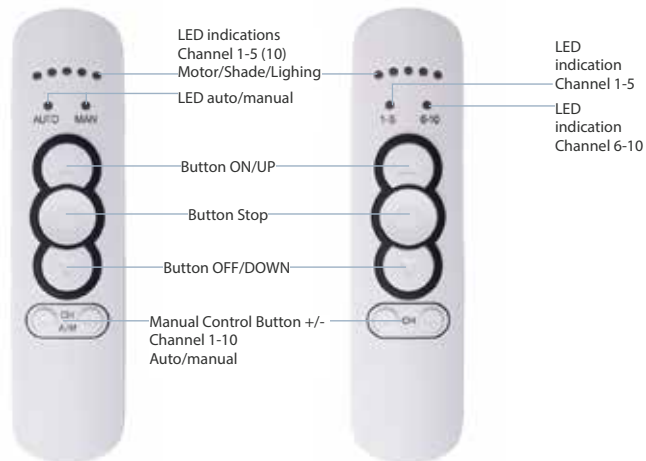

DIP Switches  
 LED Motor 1-2  
 Programm Button on MC P2

**ENTER PROGRAMMING MODE ON MC P2**

- Press the Prog. button for 3 seconds until the red LED flashes. **Programming mode will now remain open for 2 minutes.**
- You can now program a radio transmitter for motor 1. The programming mode will close after VRS transmitter has been added.

**TO SELECT OTHER CH./PROGRAM OTHER MOTOR:**

- Briefly press Prog. button, the blue LED flashes for Motor 2
- Briefly press Prog. button, the pink LED flashes for Motor 1+2



**NOTE**

The distance between two control units must be at least 50 cm to ensure reliable operation of VRS remote controls.

## PROGRAMMING VRS TRANSMITTER

**FUNCTIONS, PROGRAMMING AND CANCELING THE REMOTE CONTROL SETTINGS**

**CHANGE CHANNEL**

Manual Control Button x1 + or -



Use the Button  $\oplus \ominus$  to select the Channel. The selection is saved immediately.

The LEDs show the current selected channel.

**SWITCHING FROM AUTO TO MANUEL MODE**

Press and hold - then + x3s



The LEDs AUTO or MAN and the channels will light up briefly.

**PAIR THE TRANSMITTER TO THE CONTROL BOX**

Example: Program the radio remote control to "Ch.1" = motor 1:

Select Channel Press + or - Button x1



The LEDs show the current selected channel.

Press Prog. Button on MC P2 Modbus VRS x3s



Until the red LED ● flashes.

Press ON/UP, OFF/DOWN or Stop x1



The pink LED on the MC P2 VRS will light up (for 3 seconds) to indicate that programming was successful.

Motor 1 channel can now be operated.

**AFTER THAT: CHOOSE BETWEEN JOG MODE AND CONTINUOUS MODE**

Briefly press the ON/UP or OFF/DOWN button x1



= Jog mode

Press the ON/UP or OFF/DOWN button x3s



= Continuous mode

## PROGRAMMING VRS TRANSMITTER

### CANCEL REMOTE CONTROL SETTINGS / CANCEL ONE MOTOR ASSIGNMENT

Example: Cancel the remote control to "Ch.1" = motor 1:

Select Channel:  
Press + or - Button x1



The LEDs show the current selected channel.

Press Prog. Button on MC  
P2 Modbus VRS x3s



Until the red LED ● flashes.

Press Prog. Button  
x1(+)



until the displayed LEDs flash

Press Stop x1



The pink LED on the MC P2 VRS will light up (for 3 seconds) to indicate that cancelling was successful.

### CANCEL ALL REMOTE CONTROL SETTINGS

Press Prog. Button on MC  
P2 Modbus VRS x10s



The pink LED on the MC P2 VRS will light up (for 1 second) to indicate that cancelling was successful.

### FUNCTIONS, PROGRAMMING AND CANCELLING THE WALL-MOUNTED VRS TRANSMITTER

#### BUTTON DESCRIPTION



#### NOTE

Available as VRS Switch 1 and VRS Switch 2.

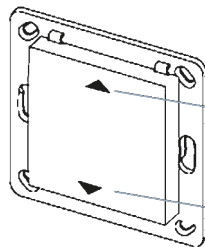

motor control

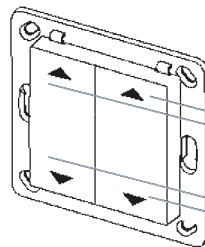

motor control

ON / UP  
Channel 2  
Channel 1

OFF / DOWN  
Channel 2  
Channel 1



#### NOTE

STOP by pressing the opposite button.

## PROGRAMMING VRS TRANSMITTER

### FUNCTIONS, PROGRAMMING AND CANCELLING THE WALL-MOUNTED RADIO TRANSMITTER

#### BUTTON DESCRIPTION



#### INSTALLATION NOTE

While installing the wall remote, please ensure that the arrow on the back is facing the ceiling.



Arrow on the back



Prog. button (on the back of the wall-mounted radio transmitter)

### PAIR THE TRANSMITTER TO THE CONTROL BOX

#### RESET / CANCEL ALL TRANSMITTER

To pair the VRS wall-mounted transmitter, please follow the steps previously described for pairing the VRS remote control:

- Procedure: identical to the VRS remote control
- Note: same functions, same pairing process

### CANCEL THE WALL-MOUNTED RADIO TRANSMITTER SETTINGS

Example: Cancel the remote control to "Ch.1" = motor 1:

Press Prog. Button on MC  
P2 Modbus VRS x3s



Until the red LED ● flashes.

Press Prog. Button  
x1(+)



Press ON/UP or OFF/  
DOWN x5s

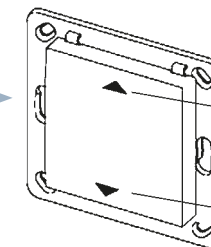

The pink LED on the MC P2 VRS will light up (for 3 seconds) to indicate that cancelling was successful.

## WARRANTY / MAINTENANCE

Principally, the General Terms and Conditions of the manufacturer, Vestamatic International GmbH apply. The terms and conditions are part of the sales documents and handed over to the operator upon delivery.

Liability claims for personal or material damages are excluded when they can be attributed to one or more of the following causes:

- Unintended use of the product.
- Improper installation, commissioning, or operation of the product
- Non-compliance with the specifications.
- Non-observance of the safety provisions and instructions of the Operating Instructions.
- Operation of the product with improperly installed connections, defective safety devices or improperly installed safeguards.
- Modifications to the product.

This product is maintenance-free.