



INSTALLATION MANUAL

Juno motors

Deze motoren zijn speciaal ontworpen voor plissé systemen en vouwgordijnen.

This manual is suitable for the following types of motors:

- BJE24S
- BJE24D

Read the manual before starting the installation. Failure to follow the instructions may result in defects that cannot be claimed under warranty.

Visit our website www.brel-home.com for more information



Scan the QR code to view the manual and instruction videos

Table of contents

Warnings	2
Wiring	3
Installing and charging the motor	3
Controlling with the BREL HOME app	3
Technical data Juno motors	4
Functions of the remote control	4
Initial installation of the motor	5
Changing settings	7
Functions of the P1 key	9

Warnings

Declaration of Conformity

This product complies with the essential requirements of the following European directives:

Radio Equipment Directive (RED) 2014/53/EU: Meets the requirements for radio communications, such as safety, health, and efficient use of the radio spectrum.

Electromagnetic Compatibility (EMC) Directive 2014/30/EU: Meets electromagnetic emission and immunity standards to prevent interference.

Restriction of Hazardous Substances Directive (RoHS) 2011/65/EU: The product complies with the directives relating to the use of hazardous substances.

Machinery Directive (MD) 2006/42/EC: Meets the safety requirements for the design and manufacture of machinery, including mechanical and electrical safety.

Note: This document is a summary. Please refer to the full Declaration of Conformity for detailed information.



Wiring

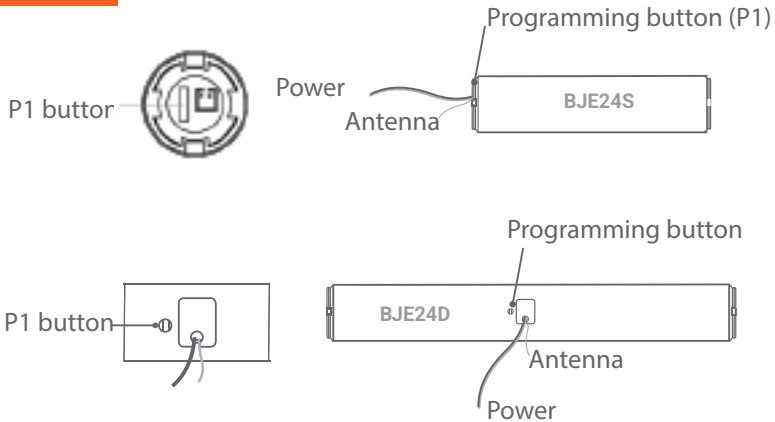

Installation and charging of the motor

This installation has usually already been carried out at the factory.

Press the adapter into the end of the motor. Place the motor brackets around the motor and check that they click into place. Then place the motor in the top rail of the system. Make sure that the motor cannot shift by clamping the axle or securing the motor.

The motor must be charged with an external 12V battery (DC-1201, DC-1277, DC-1278, DC-1329, DC-1330 or DC-1340) or with a transformer (DC-201, DC-202, DC-203, DC-232W or DC-233W).

Control with the BREL HOME app

The Juno motors can be controlled with your mobile phone in combination with a Home Box. The Home Box Mini is a USB WiFi dongle, Home Box Duo is a WiFi hub RS485 suitable for mono- and bi-directional and the Home Box Ultra is with WiFi and UTP/PoE.

In this App you can create time functions and scenarios. The BREL HOME app can be connected to Siri, Google Home and Alexa.

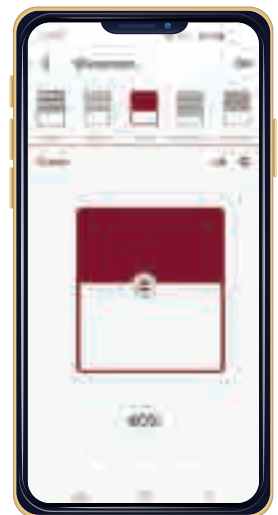

Technische data van de motor

	BJE24S	BJE24D
Input	JST male	JST male
Working voltage	12V	12V
Charging voltage	12V	12V
Power	8W	14W
Amperage	1.00A	1.18A
Force (Nm)	0.6	0.8
Speed (Rpm)	34	34
Motor length (mm)	133	190
Motor diameter (mm)	24	24
Antenna (mm)	170	170
Cable (mm)	350	350

The following specifications apply to all Juno motors:



Frequency	433 MHz
Range	25m binnenruimte tot 100m buitenruimte
Capacity	10 kanalen of zenders
IP value	IP20
Working temperature	-10°C tot +85°C

Transmitter functions



There are two P2 keys, it doesn't matter which one you use



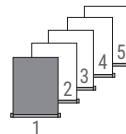

Programming the first remote control/channel

-  The remote control can transmit 15 channels and therefore control multiple blinds. First, select a channel for operating the relevant roller blind. Make sure that you select a free channel (we recommend only 1 product per channel).
-  This remote has also channel 0. All blinds programmed in channel 1~15 are automatically programmed in this channel 0 and can be operated all at once.
-  In case you have selected the wrong channel, go to **Resetting factory settings**.



► Select the desired channel.

Step 1 Establishing connection



-  If you do not start programming within 10 seconds, the motor will exit programming mode.
-  During programming you must press the key briefly. If you need to hold it for a long time, this will be stated
-  The motor confirms each completed step with an up and down movement. (‡)
-  If a procedure does not go as planned, wait 20 seconds and then start again.



Hold down the P1 key until the motor moves up/down.

Houd de stop toets ingedrukt totdat de motor 2x op/neeer beweegt.

afstandsbediening/
kanaal is toegevoegd

-  If NO end positions have been set, the motor will move in pulse mode. Then go to step 3.
-  If end positions have been set, check the end positions. If correct, go to step 5.
Warning: If the end positions are not correct, go to option A

Step 2 Reverse the direction of rotation (only if it is not correct)

Only possible if no end positions have been set

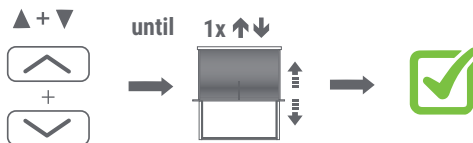



Press the UP and DOWN keys simultaneously until the motor moves up/down.

The direction of rotation of the motor has been adjusted.

-  If no response, check whether the transmitter is blocked.

Step 3 Setting the end position

-  To move the motor one step: briefly press the UP or DOWN key
-  To move the motor continuously: press the UP or DOWN key for 3 seconds (NOTE! Press STOP in time)

1. Set the desired top position

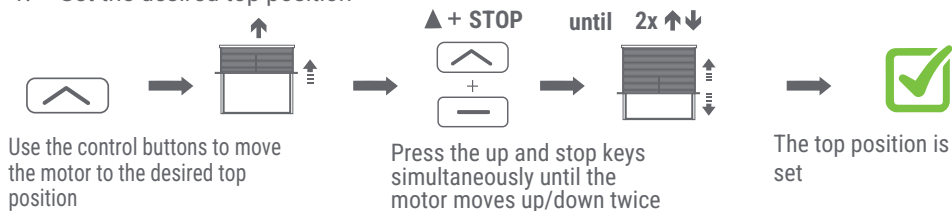

2. Set the desired bottom position

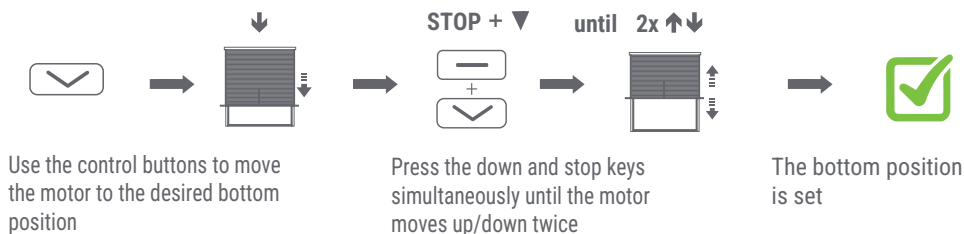

 **The motor is now ready for use**

Step 4 Setting the favorite position (if desired)

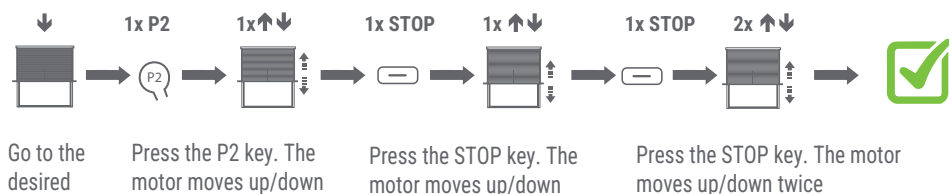

 **Press and hold the stop button for 3 seconds to go to the favorite position.**

 **Repeat this procedure to delete the favorite position.**

Change settings

Adjusting the top position

 If adjustment is not possible, check the lock function or reset the motor



Adjusting the bottom position

 If adjustment is not possible, check the lock function or reset the motor

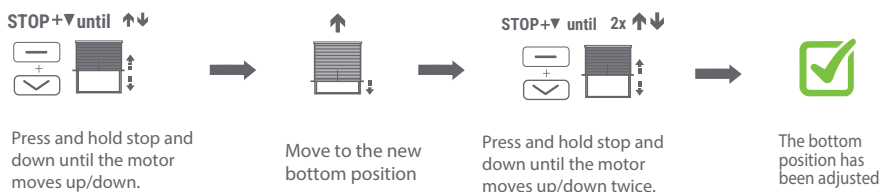

Change speed

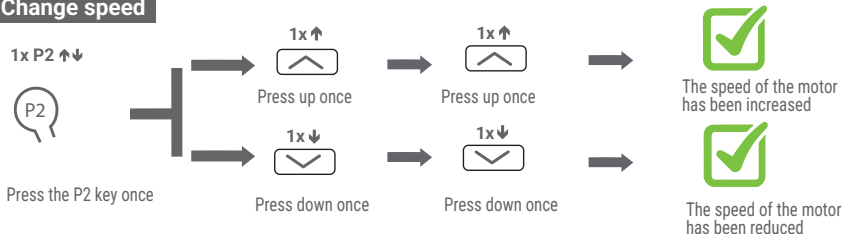

 The motor is set to the highest speed and the slow stop is activated

 To deactivate the slow stop, the motor must first be at the lowest speed. Because the motor is at the highest speed, you must first reduce the speed twice to set the motor to the lowest speed. Then reduce the speed once more to deactivate the slow stop. To activate the slow stop again, increase the speed twice until the motor is at the highest speed. Then increase the speed once more to activate the slow stop.

Instellingen wijzigen

Puls mode

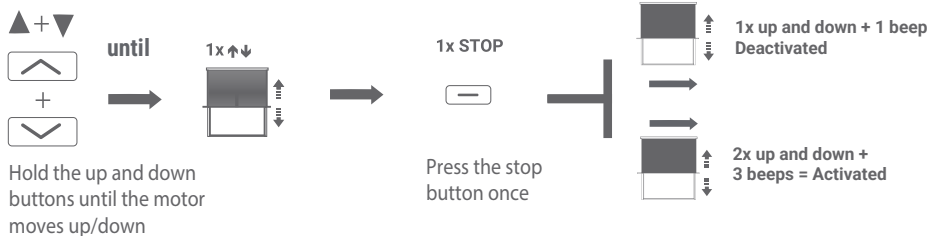

Registering an extra remote control/channel

Only possible if the end positions have been set

a = Existing remote control/channel

b = New remote control/channel

Via the existing transmitter

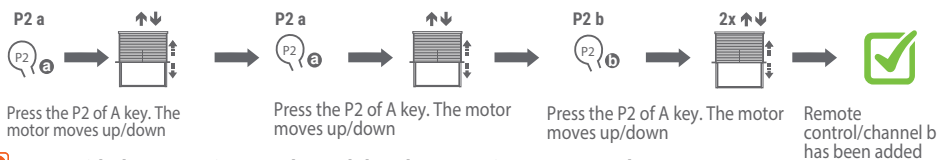

i Start with the transmitter or channel that the motor is programmed to

i To delete a transmitter/channel repeat the procedure

Via P1 key (If the old transmitter is lost or broken)

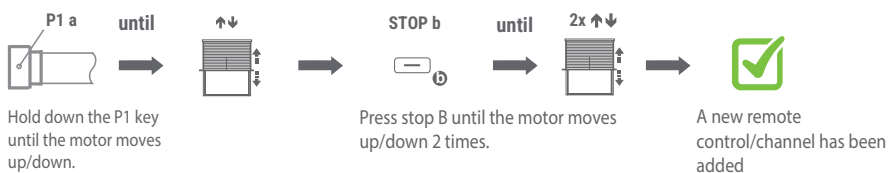

i Start with the transmitter or channel that the motor is programmed to

i To delete a transmitter/channel repeat the procedure

Functions of the P1 key can be used as a control button in case of emergency



The motor moves up, stops or moves down when you press the P1 key

Press the P1 key briefly once

Turn off the receiver

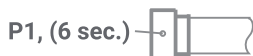

until

2nd ↑↓



Hold the P1 key until the motor has moved up/down for the 2nd time.
To activate the receiver again, briefly press P1 once
To reactivate, briefly press P1 once.

The receiver is turned off

Changing the direction of rotation



until

3rd ↑↓



Hold the P1 key until the motor has moved up-down for the 3rd time.

The direction of rotation is reversed

Reset to factory settings



until

4th ↑↓



Hold the P1 key until the motor has moved up/down for the 4th time.

Reset to factory settings

 To reprogram the motor go to step 1